

Serial Numbers / Seriennummer / Números de Serie / Numéros de Série:

6736

This manual is divided into the sections listed below:
Diese Betriebsanleitung ist in folgende Abschnitte eingeteilt:
Este manual contiene las siguientes secciones:
Ce manuel contient les sections suivantes:

- 1A** Operation (*English*)
- 1B** Betriebsanweisungen (*Deutsch*)
- 1C** Operación (*Español*)
- 1D** Instructions d'Opération (*Français*)

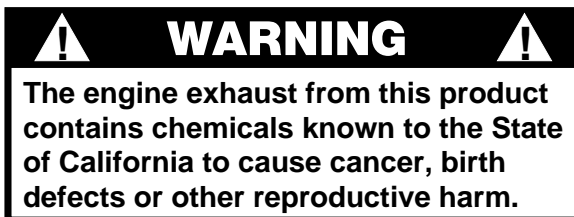

1012SD26

This manual provides information and procedures to safely operate and maintain this WACKER model. For your own safety and protection from injury, carefully read, understand and observe the safety instructions described in this manual. THE INFORMATION CONTAINED IN THIS MANUAL WAS BASED ON MACHINES IN PRODUCTION AT THE TIME OF PUBLICATION. WACKER CORPORATION RESERVES THE RIGHT TO CHANGE ANY PORTION OF THIS INFORMATION WITHOUT NOTICE.

Diese Betriebsanleitung enthält Informationen und Verfahren, um dieses WACKER Gerät sicher zu bedienen und zu warten. Für Ihre Sicherheit und zur Verhinderung von Verletzungen, diese Betriebsanleitung bitte genau durchlesen und die Angaben befolgen. DIE HIERIN ENTHALTENEN INFORMATIONEN SIND AKTUELL ZUM ZEITPUNKT DER VERÖFFENTLICHUNG. ÄNDERUNGEN VORBEHALTEN.

Este manual contiene la información y los procedimientos que son necesarios para operar y mantener esta máquina WACKER. Para su seguridad y protección, lea por favor este manual cuidadosamente y observe todas las instrucciones de seguridad descritas en este manual. TODA LA INFORMACION EN ESTE MANUAL SE BASA EN MAQUINAS EN PRODUCCION VIGENTE A PARTIR DE LA FECHA DE PUBLICACION. TODOS DERECHOS RESERVADOS POR WACKER CORPORACION.

Ce manuel contient l'information et les procédés pour opérer et entretenir sans accident cette machine WACKER. Pour assurer votre sécurité et protéger votre santé, il est essentiel de lire, comprendre, et observer les consignes de sécurité. L'INFORMATION COMPRISE DANS CE MANUEL SE BASE SUR MACHINES MANUFACTUREES AU MOMENT DE LA PUBLICATION. "TOUS DROITS RESERVES".

Identification Plate / Typenschild / Placa de Identificación / Plaque d'Identité

An identification plate listing the Model Number and Serial Number is attached to each unit. Please record the information found on this plate so it will be available should the identification plate become lost or damaged. When ordering parts or requesting service information, you will always be asked to specify the model and serial number of the unit.

Ein Typenschild mit Modell- und Seriennummer ist an jedem Gerät angebracht. Die Daten von diesem Schild bitte notieren, damit sie auch bei Verlust oder Beschädigung des Schildes noch vorhanden sind. Die Serien- und Modellnummer sind stets nötig, um Ersatzteile zu bestellen oder wenn Service-Information gewünscht wird.

Una placa de identificación con los números de serie y modelo se encuentra en la máquina. No debe quitar esta placa. Anote bien los datos en esta placa, por favor, en caso que la placa de identificación se pierda. En todos los pedidos para repuestos necesita siempre el número de serie y el número del modelo de la máquina.

Une plaque d'identité s'attache à chaque machine. Consignez les données de cette plaque pour les maintenir en face de perte ou dommage. Utilisez les numéros de série et les numéros de modèle de la machine pour commander des pièces détachées ou si vous desirez service-information.

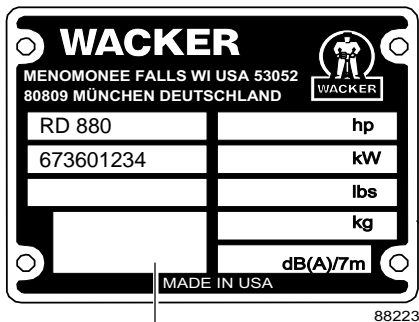

Model Year
Baujahr
Año de fabricación
Année de modèle

Serial Number / Seriennummer /
Número de Serie /
Numéro de Série

6736 01234

Production Sequence
Produktionsfolge
Serie de producción
Cycle de production

Model Identification
Modellidentifizierung
Identificación de modelo
Identification de modèle

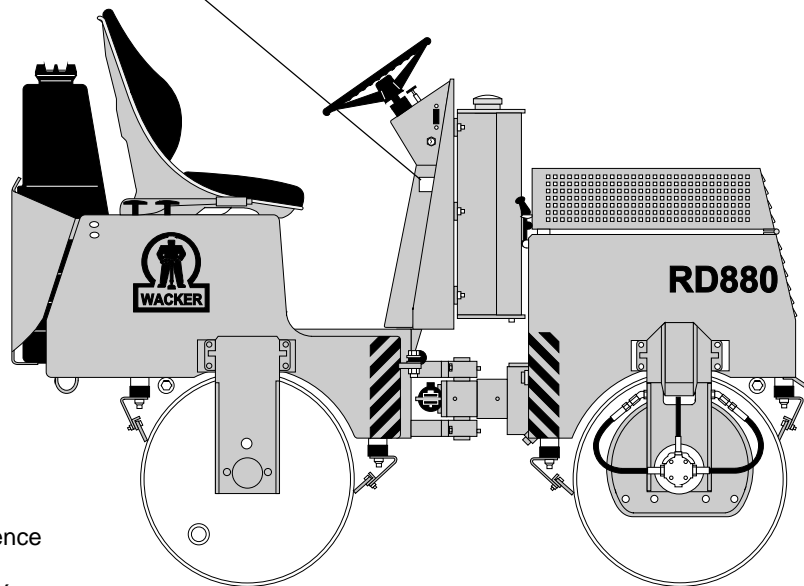

1004SD45

Table of Contents

1.1	Safety Notes	1A-2
1.2	Laws Pertaining to Spark Arresters	1A-2
1.3	General Precautions	1A-3
1.4	Engine Safety	1A-3
1.5	Operating Safety	1A-4
1.6	Lubrication Requirements	1A-4
1.7	Technical Data	1A-5
1.8	Operation & Service Locations	1A-6
1.9	Application	1A-8
1.10	Before Starting	1A-8
1.11	Starting	1A-8
1.12	Direction / Speed Control	1A-8
1.13	Vibration	1A-8
1.14	Braking Machine	1A-8
1.15	Stopping/Parking	1A-9
1.16	Parking Brake	1A-9
1.17	Watering System	1A-9
1.18	Lockarm	1A-9
1.19	Adding Ballast To Rear Drum	1A-9
1.20	Engine Maintenance	1A-10
1.21	Maintenance Schedule	1A-10
1.22	Engine Lubrication	1A-11
1.23	Servicing Air Cleaner	1A-11
1.24	Carburetor Adjustment	1A-11
1.25	Articulated Joint	1A-12
1.26	Rear Drum	1A-12
1.27	Exciter Lubrication	1A-12
1.28	Hydraulic System Cleanliness	1A-13
1.29	Hydraulic Oil Requirements	1A-13
1.30	Hydraulic Fluid Level	1A-14
1.31	Suction Filter (Exciter Pump Inlet)	1A-14
1.32	Changing Hydraulic Fluid & Filter	1A-14
1.33	Bleeding the Hydraulic System	1A-15
1.34	Scraper Bars	1A-15
1.35	Towing	1A-16
1.36	Storage	1A-16
1.37	Hydraulic Diagram	1A-17
1.38	Hydraulic Schematic	1A-18
1.39	Wiring Diagram	1A-19
1.40	Electrical Schematic	1A-20

Keep this manual or a copy of it with the machine. If you lose this manual or need an additional copy, please contact WACKER Corporation.

This machine is built with user safety in mind; however, it can present hazards if improperly operated and serviced. Follow operating instructions carefully! If you have questions about operating or servicing this equipment, please contact WACKER Corporation.

1.1 Safety Notes

This manual contains NOTES, CAUTIONS, and WARNINGS which must be followed to prevent the possibility of improper service, damage to the equipment, or personal injury.

Notes: *Notes appear in italics and contain additional information important to a procedure.*

CAUTION: Cautions provide information important to prevent errors which could damage machine or components.



WARNING

Warnings warn of conditions or practices which could lead to personal injury or death!

1.2 Laws Pertaining to Spark Arresters

Notice: Some states require that in certain locations, spark arresters be used on internal combustion engines. A spark arrester is a device designed to prevent the discharge of sparks or flames from the engine exhaust. It is often required when operating equipment on forested land to reduce the risk of fires. Consult the engine distributor or local authorities and make sure you comply with regulations regarding spark arresters.

1.3 General Precautions

For your protection, the protection of others, and to prevent damage to the unit, read, understand, and follow all safety instructions. Failure to follow the safety notes listed below could cause damage to the equipment or result in personal injury.

 **WARNING**

- **NEVER** allow unfamiliar or inexperienced personnel to operate the machine.
- **NEVER** operate a defective unit in need of service or repair.
- **NEVER** operate a unit with safety devices or guards removed.
- **NEVER** operate with fuel cap loose or missing.
- **NEVER** leave machine running unattended.
- **NEVER** modify the equipment without express written approval of the manufacturer.
- **NEVER** use the machine for applications for which it was not designed.
- **NEVER** run machine indoors or in areas with limited ventilation, unless sufficient ventilation or exhaust hoses can be provided.
- **ALWAYS** dress appropriately for job conditions and wear specified safety devices such as a hard hat, goggles, and ear protection where required.
- **ALWAYS** keep hands, feet, and clothing away from moving parts when operating or servicing equipment.
- **ALWAYS** turn engine off when leaving machine unattended.
- **ALWAYS** drain fuel tank when transporting machine long distances.
- **ALWAYS** replace all missing and hard-to-read decals.
- **ALWAYS** check and tighten all external fasteners at regular intervals.

1.4 Engine Safety

Internal combustion engines present special hazards during operation and fueling! Failure to follow the safety guidelines described below could result in severe injury or death.

 **WARNING**

- **DO NOT** run engine indoors or in an area with poor ventilation unless exhaust hoses are used.
- **DO NOT** fill fuel tank near an open flame, while smoking, or while engine is running.
- **DO NOT** fill fuel tank in an enclosed area with poor ventilation.
- **DO NOT** touch or lean against hot exhaust pipes or engine cylinder.
- **DO NOT** operate with the fuel tank cap loose or missing.

Keep area around hot exhaust pipes free of debris to reduce the chance of an accidental fire.

1.5 Operating Safety

Familiarity and proper training are required for the safe operation of mechanical equipment! Equipment operated improperly or by untrained personnel can be dangerous! Read the operating instructions and familiarize yourself with the location and proper use of all controls. Inexperienced operators should receive instruction from someone familiar with the equipment before being allowed to operate the machine.



- Check that all safety devices and guards are in place before starting machine! **DO NOT** operate machine if any safety devices or guards are missing or inoperative.
- Disengage and stow locking bar for the articulated joint before operating machine. The machine cannot be steered when the locking bar is engaged.
- Check that all controls are functioning properly immediately after start-up! **DO NOT** operate machine unless all controls operate correctly.
- Remain aware of changing positions and movement of other equipment and personnel on the jobsite.
 - Remain seated at all times while operating machine.
- Remain aware of changing surface conditions and use extra care when operating over uneven ground, on hills, or over soft or coarse material. The machine could shift or slide unexpectedly.
- Use caution when operating near the edges of pits, trenches or platforms. Check to be sure ground
 - surface is stable enough to support the weight of the machine and there is no danger of the roller sliding, falling or tipping.
 - Set parking brake before starting and after stopping machine! If machine must be parked on an incline, also
 - block drums.
 - Look behind you when operating roller in reverse! **Never** assume it is clear behind you.
-

1.6 Lubrication Requirements

	Type	Quantity
Engine Crankcase	SAE 10W30 SG, SF, or SE rated	3.5 pts. (1.6 liters)
Hydraulic System	Premium grade, Anti-wear hydraulic fluid 10W30	5.7 U.S. gal. (21.6 liters)
Exciter	10W30	16 oz. (470 ml)
Rear Drum Drive Bearing	Shell Alvania No. 2 Grease (1 grease fitting)	2-3 shots with hand-held grease gun
Articulated Joint	Shell Alvania No. 2 Grease (4 grease fittings)	
Front Drum Drive Bearings	Sealed Bearings—No lubrication required	

1.7 Technical Data

Engine

Engine Type		2 Cylinder, Air Cooled, 4-cycle, Gasoline Engine
Engine Make		Briggs & Stratton
Engine Model		Vanguard 303447
Power	Hp (kW)	16 (11.9)
Displacement	in ³ (cm ³)	29.3 (480)
Spark Plug		Champion RC12YC
Electrode Gap	in. (mm)	0.030 (0.76)
Starter	type / V	Electric / 12
Alternator	Amp	10
Air Cleaner	type	Dual Element
Operating Speed	rpm	3200
Valve Clearance (Cold)	in. (mm)	0.004–0.006 (0.10–0.16)
Battery	V / Size	12 / 22NF
Fuel	type	Lead-free Regular Gasoline (Min. 77 Octane)
Fuel Capacity	gal. (l)	6.3 (24)
Fuel Consumption	gal. (l)/hr.	1.2 (4.6)

Roller

Dry Weight	lb.(kg)	2040 (925)
Overall Size l x w x h	in. (mm)	82 x 41 x 60 (2080 x 1040 x 1530)
Drum Width	in. (mm)	35.4 (900)
Curb Clearance right/left	in. (mm)	18.4 / 8.1 (470 / 205)
Water Tank Capacity	gal. (l)	40 (151)
Outside Turning Radius	ft. (m)	9.2 (2.8)
Forward / Reverse Speed ¹	ft. (m) / min.	0–414 (0–126) ¹
Gradeability		27% (12°)
Vibration Frequency	vpm (Hz)	3900 (65)

¹ Maximum values for forward and reverse speeds are based on the machine traveling on a firm, level surface and engine operating at full throttle.

1.8 Operation & Service Locations

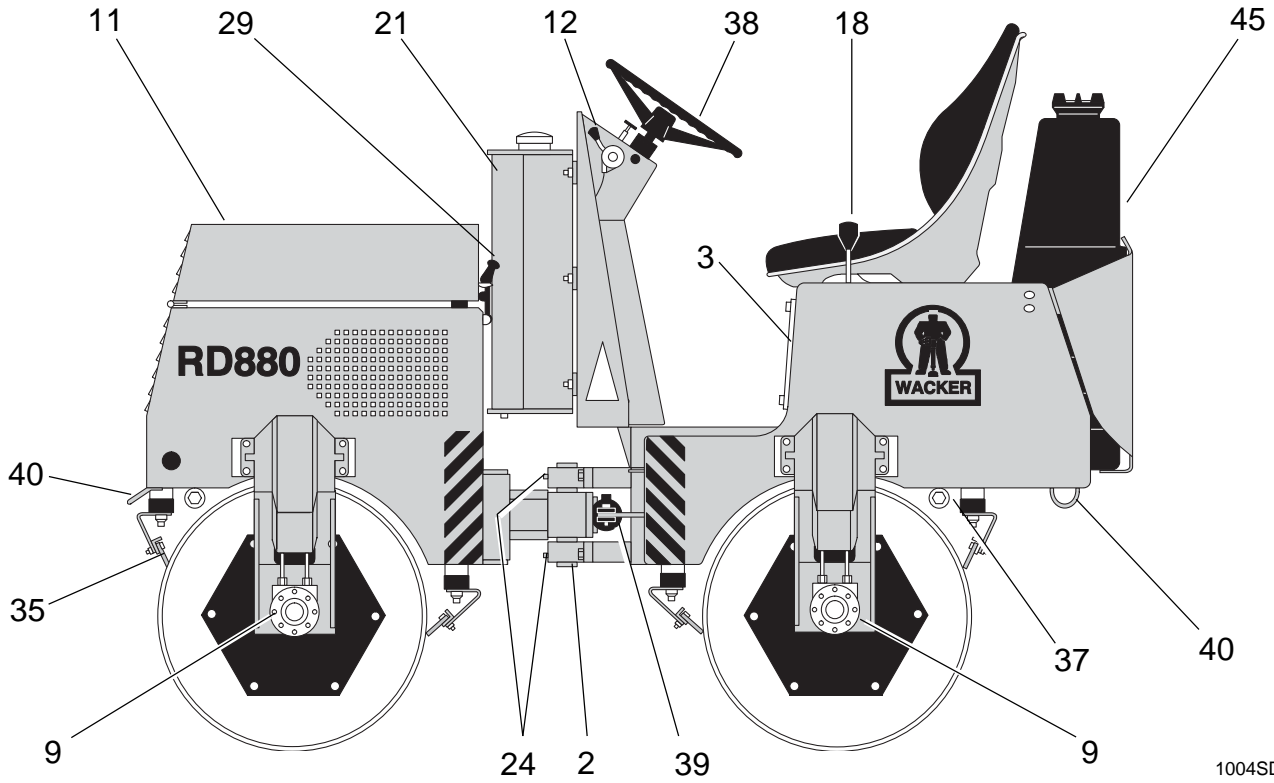

1004SD44

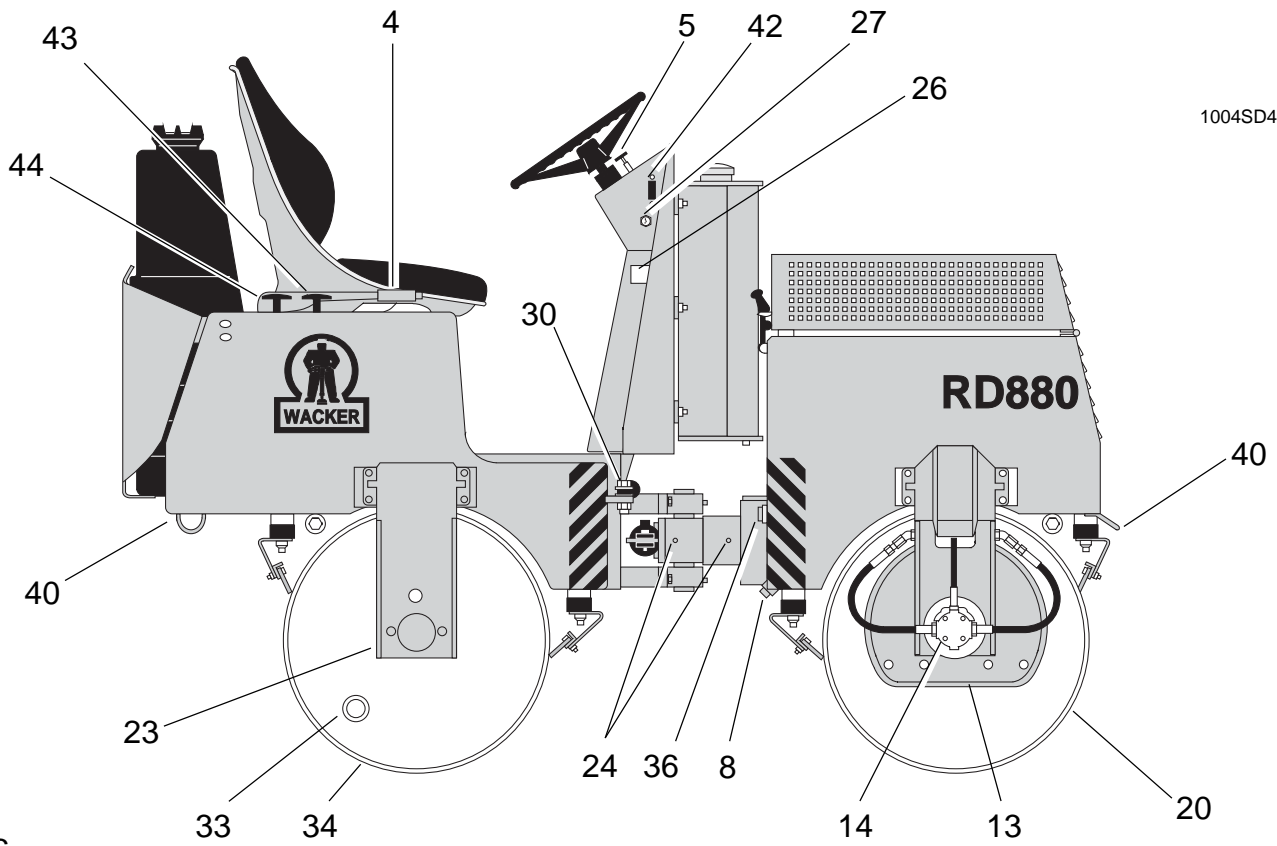

1004SD45

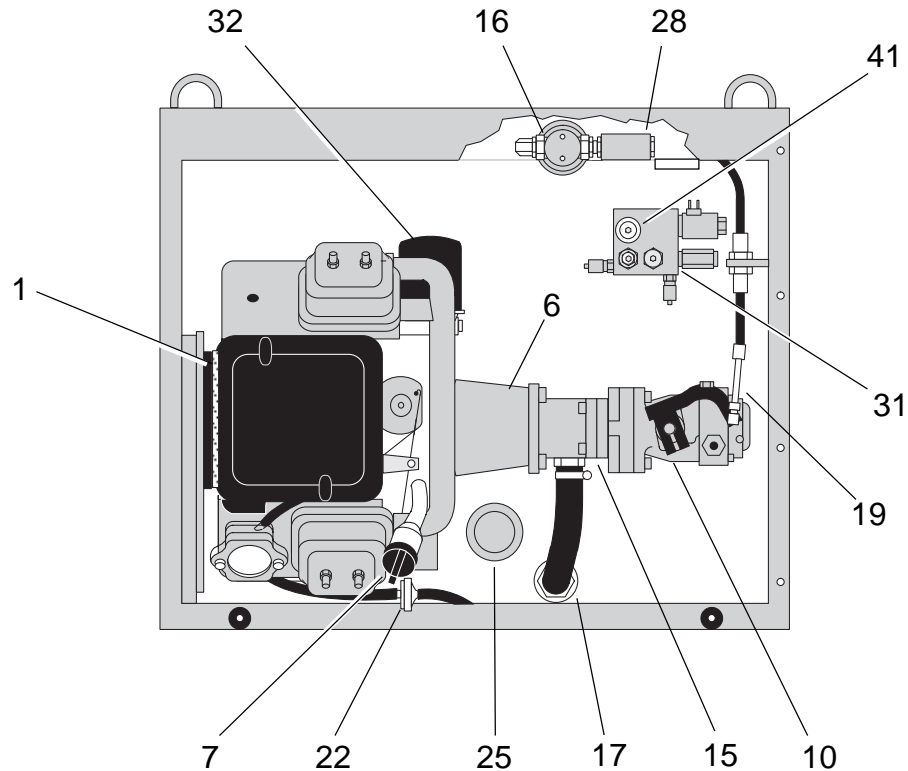

1004SD46

Engine Compartment**Ref. Description**

1.	Air Cleaner
2.	Articulated Joint
3.	Battery Access Cover
4.	Brake Lever
5.	Choke Lever
6.	Coupling - Engine
7.	Dipstick
8.	Drain Plug - Hydraulic Tank
9.	Drive Motor
10.	Drive Pump
11.	Engine Hood
12.	Engine Throttle Control
13.	Exciter Drain Plug - (Section 1.27)
14.	Exciter Motor
15.	Exciter/Steering Pump
16.	Filter - Return Line
17.	Filter - Suction Line
18.	Forward/Reverse Control
19.	Forward /Reverse Control Cable
20.	Front Drum - Vibratory
21.	Fuel Tank
22.	Fuel Filter
23.	Grease Fitting - Rear Drum (Section 1.26)

Ref. Description

24.	Grease Fittings - Articulated Joint (4 places)
25.	Hydraulic Tank Fill Port
26.	Identification Plate
27.	Ignition Switch
28.	Inlet Line Check Valve (Back Pressure Valve)
29.	Latch
30.	Lockarm
31.	Manifold Assembly (Valve Block)
32.	Oil Filter - Engine
33.	Rear Drum Fill/Drain Plug
34.	Rear Drum - Static
35.	Scraper Bar (4 places)
36.	Sightglass - Hydraulic Tank
37.	Sprinkler
38.	Steering
39.	Steering Cylinder
40.	Tiedown Lug (4 places)
41.	Towing Valve
42.	Vibration Switch
43.	Water System Control - Front Drum
44.	Water System Control - Rear Drum
45.	Water Tank

1.9 Application

This machine is designed as a lightweight roller to be used in the compaction of sublayers and finish layers of asphalt on roads, driveways, parking lots, and other types of asphalt covered surfaces.

1.10 Before Starting

Before starting machine check the following:

1. Engine Oil Level
2. Condition of Air Cleaner
3. Fuel Level
4. Water Level
5. Hydraulic Fluid Level

1.11 Starting

1. Check to be sure vibration switch **(a)** is off.
2. Pull out choke knob **(b)**.
3. Set forward/reverse control in the neutral position **(c₂)**.

Note: Roller will not start unless forward/reverse control is in neutral.

4. Check that parking brake is set **(d₁)**.
5. Move throttle control to about one quarter open **(e₁)**.
6. Turn ignition switch **(f)** to start engine.
7. Push choke knob in gradually as engine warms up.

Allow engine to warm up for a few minutes before operating roller.

1.12 Direction / Speed Control

The forward/reverse lever controls both the direction and speed of the roller. Use the control lever, rather than the throttle, to control the speed of the machine while compacting.

Speed is controlled by the amount the lever is moved in the direction of travel—forward **(c₁)** or reverse **(c₃)**.

During operation, run machine at **full** throttle. This ensures maximum travel speeds and will produce the best compaction results. Operating the machine at slower engine speeds will reduce compaction and slow down machine functions.

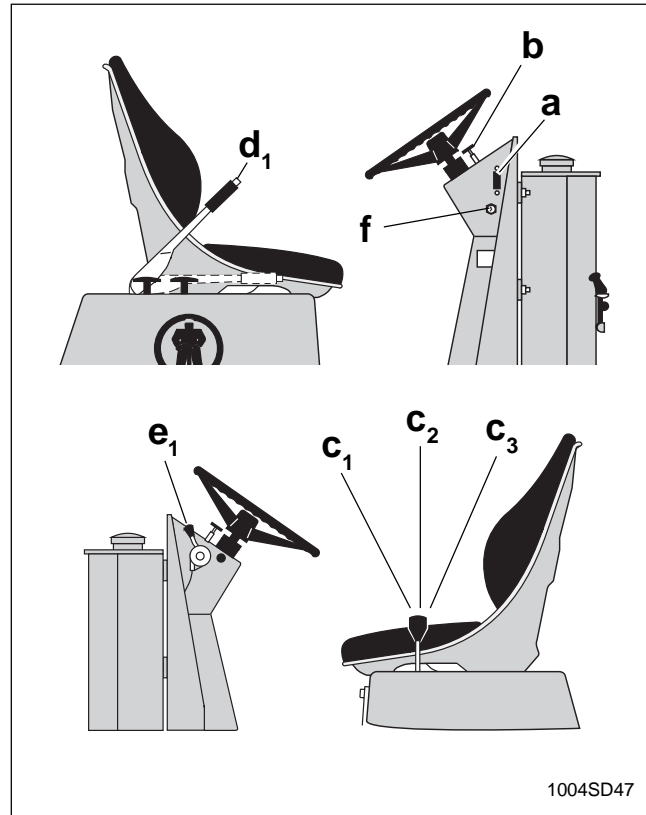

1.13 Vibration

Vibration is turned “ON” or “OFF” by a rocker switch **(a)** located above the ignition switch. Vibration can be turned on while operating in either forward or reverse and will remain on until switched off.

Note: Vibration will remain on even when the forward/reverse control is in neutral. When operating on asphalt, to keep surface finish smooth, turn vibration off before stopping roller.

1.14 Braking Machine

The machine will brake automatically when the control lever is returned to neutral. If machine continues to drift, shift the control level **slightly** in the opposite direction to stop movement and then return lever to neutral.

Note: The parking brake is not intended to be used to stop the machine.

1.15 Stopping/Parking

1. Turn vibration off.
2. Close both watering valves.
3. Return engine throttle to idle and allow engine to cool down.
4. Stop engine by turning ignition switch to "OFF".
5. Set parking brake.

CAUTION: Avoid parking roller on a hill or incline. If roller must be parked on a hill, block drums in addition to setting brake to prevent roller from moving.

1.16 Parking Brake

To set the brake (**g**), pull the brake lever up until brake pad engages drum. To release, push in brake release button (**h**) and lower lever. Always set parking brake before leaving machine.

The parking brake is connected to the brake pad through a solid linkage and requires no adjustment. If the brake wears beyond the engagement limit of the lever, replace the brake pad.

Note: The parking brake engages the rear drum only.

1.17 Watering System

The watering system is controlled by two levers (**i**) located to the right of the operator. Turn levers counter-clockwise to control the amount of water being applied to the drum.

1.18 Lockarm

A lockarm (**j**), located above the articulated joint, is provided to secure the front and rear halves of the roller together. Once secured, the lockarm prevents the two halves from swinging together.



WARNING

Set the lockarm before lifting the machine for transport or repairs!

To set lockarm, release it from its holder and swing it out from its stored position. Place the forward end of the arm into the hole provided in the front frame of the machine. Secure it in this position using the large cotter pin (**k**) provided.

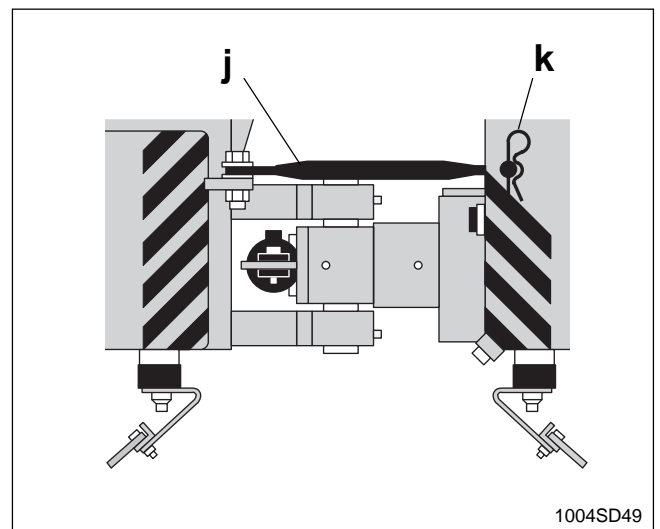
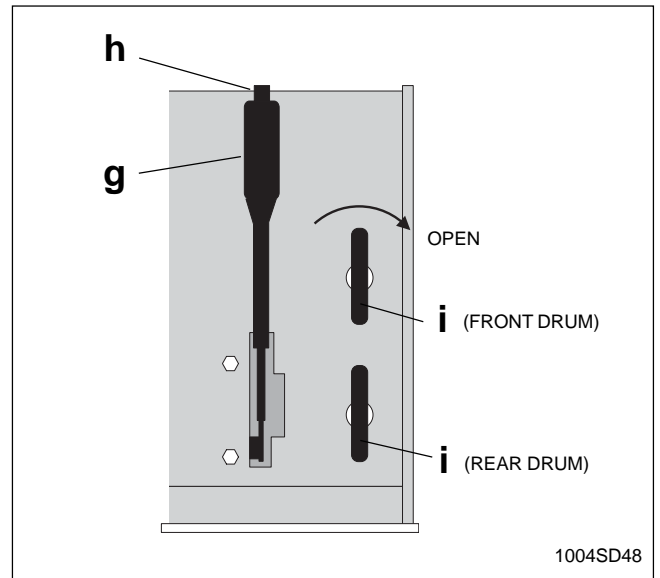

1.19 Adding Ballast To Rear Drum

The rear drum can be filled with ballast to provide additional weight. Add ballast through plug opening.

Drum Capacity: 26.5 Gal. (100 liters)

Added Weight (water ballast): 220 lbs. (100 Kg)

If water is used as ballast, add antifreeze or drain drum after use, in areas where temperatures are below freezing or may fall below freezing overnight.

1.22 Engine Lubrication

To fill crankcase - place machine on a level surface. Clean area around oil fill and remove dipstick. Pour oil **(a)** slowly checking oil level occasionally with dipstick. Fill to full mark on dipstick **(b)**. **DO NOT** overfill.

When measuring oil level, screw dipstick **(c)** firmly in place until cap bottoms on tube.

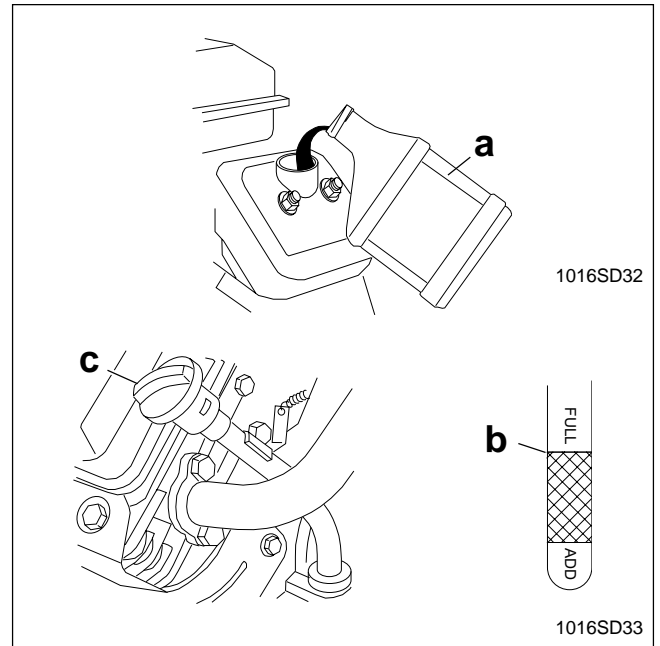

1.23 Servicing Air Cleaner

1. Remove cover **(d)**, knob **(e)**, and retaining plate **(f)**.
2. Remove foam precleaner **(g)** from filter cartridge **(h)**.
3. Wash precleaner in liquid detergent and water. Squeeze dry in a clean cloth. Saturate precleaner in engine oil, squeeze out excess oil. Replace precleaner if it is damaged or heavily soiled.
4. To clean cartridge, remove and tap lightly on a flat surface. Replace cartridge if it is damaged or heavily soiled.

Note: Do not use petroleum solvents to clean precleaner or cartridge. Petroleum type solvents will damage them. Do not use pressurized air to clean cartridge. Pressurized air can also damage the cartridge.

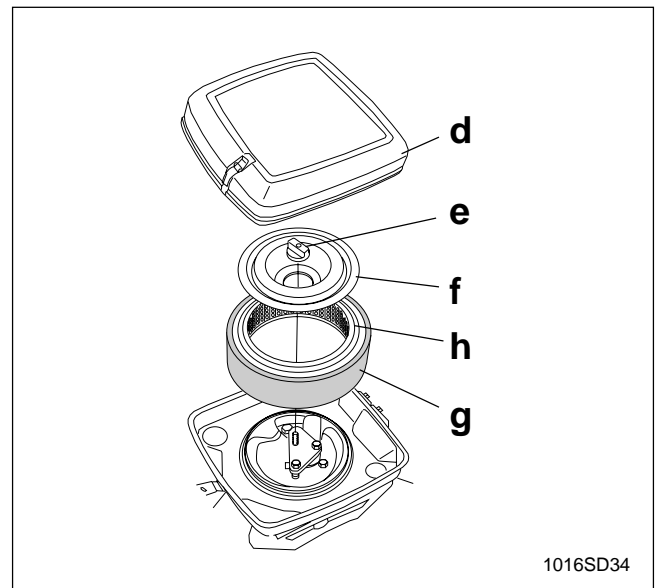

1.24 Carburetor Adjustment

Note: Air cleaner must be in place and engine warm when making adjustments to carburetor.

1. With engine running, place throttle in SLOW position and rotate carburetor throttle lever against the idle speed screw **(i)** and hold it there.
2. Turn the idle speed screw to obtain 1300 to 1500 rpm.
3. While still holding the throttle lever against the idle speed screw, turn the idle mixture valve **(j)** midway between limits.
4. Readjust the idle speed to 1200 rpm and release carburetor throttle lever. Engine should accelerate smoothly when throttle opened. If it does not, readjust idle mixture valve slightly counterclockwise.

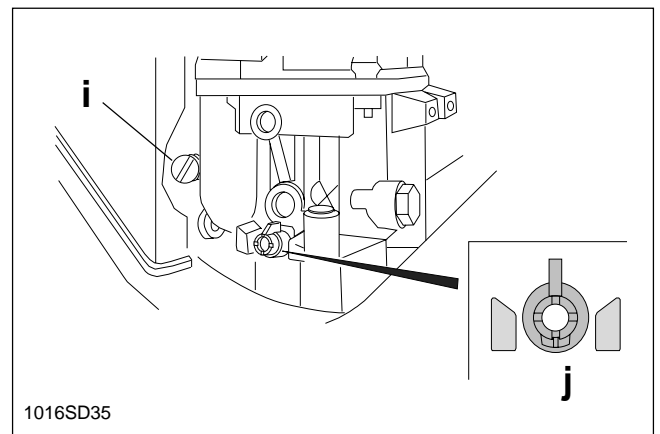

1.25 Articulated Joint

The articulated joint is equipped with four grease fittings **(a)** for lubrication. Use Shell Alvania No. 2 or an equivalent general purpose grease.

1.26 Rear Drum

The rear drum drive bearing is equipped with a grease fitting **(b)** located at the center of the drum behind the right rear drum support. Use Shell Alvania No. 2 or an equivalent general purpose grease.

1.27 Exciter Lubrication

To change oil: The exciter drain plug **(c)** is located on the right side of the front drum, behind the shockmounts. Turn the front drum until the drain plug is positioned at the bottom of rotation. Remove plug and allow oil to drain. On some machines, it may be necessary to remove the socket head screw next to the plug to allow enough room to attach a wrench. After oil has drained, rotate drum so the plug opening is at least 4–5 inches above bottom. Add oil through plug opening—**do not** overfill. See Section 1.6 *Lubrication Requirements*.

Note: To reduce the amount of time needed to drain the exciter, warm the exciter oil by running machine vibration for a few minutes. Park roller sideways on a small incline or use a screw jack to raise up the left front half of the roller so the drain plug is facing downhill.

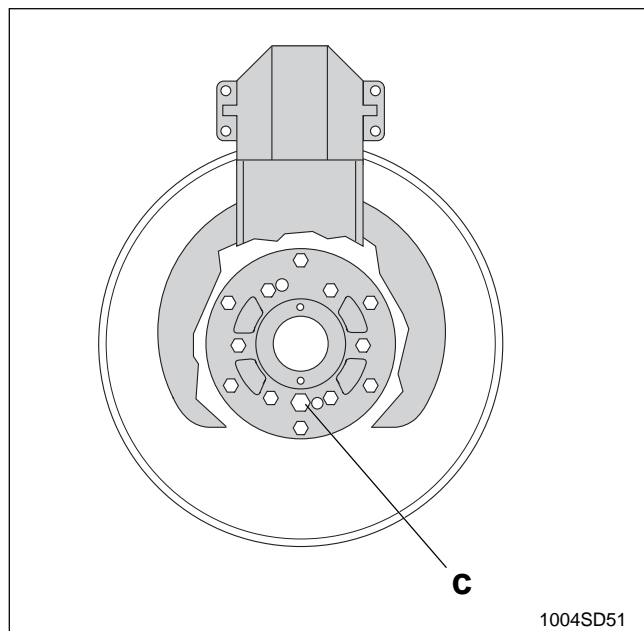
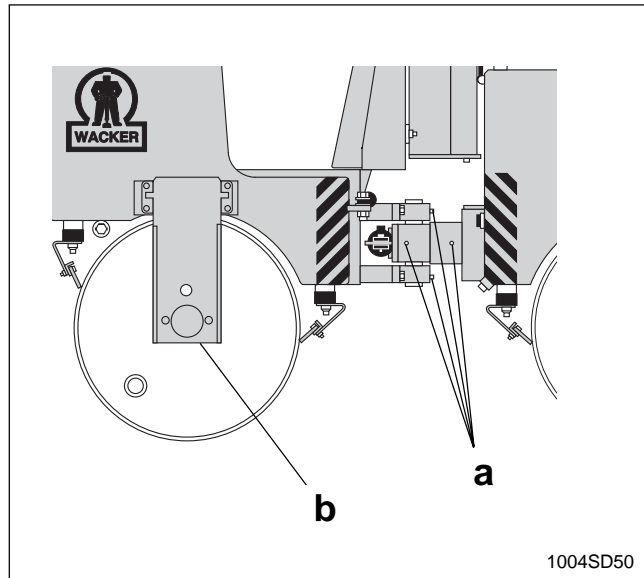

1.28 Hydraulic System Cleanliness

Keeping the hydraulic fluid clean is a vital factor affecting the service life of hydraulic components. Oil in hydraulic systems is used not only to transfer power, but also to lubricate the hydraulic components used in the system. Keeping the hydraulic system clean will help avoid costly downtime and repairs.

Major sources of hydraulic system contamination include:

1. Particles of dirt introduced when the hydraulic system is opened for maintenance or repair.
2. Contaminants generated by the mechanical components of the system during operation.
3. Improper storage and handling of hydraulic fluid.
4. Use of the wrong type of hydraulic fluid.
5. Leakage in lines and fittings.

To minimize hydraulic fluid contamination:

CLEAN hydraulic connections before opening lines. When adding oil, clean hydraulic tank filler cap and surrounding area before removing.

AVOID opening pumps, motors, or hose connections unless absolutely necessary.

PLUG or cap all open hydraulic connections while servicing system.

CLEAN and cover the containers, funnels, and spouts used to store and transfer hydraulic fluid.

CHANGE hydraulic filters and fluids at the recommended service intervals.

1.29 Hydraulic Oil Requirements

WACKER recommends the use of a good petroleum-based, anti-wear hydraulic oil in the hydraulic system of this equipment. Good anti-wear hydraulic oils contain special additives to reduce oxidation, prevent foaming, and they provide for good water separation.

When selecting hydraulic fluid for your machine, be sure to specify anti-wear properties. Most hydraulic fluid suppliers will provide assistance in finding the correct hydraulic fluid for your machine.

Avoid mixing different brands and grades of hydraulic fluids.

Most hydraulic oils are available in different viscosities. The SAE number for an oil is used strictly to identify viscosity—it **does not** indicate the type of oil (engine, hydraulic, gear, etc.).

When selecting a hydraulic oil be sure it matches the SAE viscosity rating specified and is intended to be used as an hydraulic oil. See Section 1.6 *Lubrication Requirements*.

1.30 Hydraulic Fluid Level

A hydraulic oil level sightglass **(a)** is located near the bottom right side of the machine below the engine compartment.

Check that the hydraulic fluid level is visible in the sight glass. If it is not, add fluid through the filler port **(b)** inside the engine compartment. Use only clean hydraulic fluid.

Thoroughly clean top of filler cap before removing it from the tank. Although the filler port is equipped with a screen to trap large particles, care should be taken to prevent smaller dirt particles from entering the system.

If hydraulic fluid continually needs to be added, inspect hoses and connections for possible leaks.

1.31 Suction Filter (Exciter Pump Inlet)

A hydraulic filter **(c)** is located in the hydraulic tank in-line with the exciter pump inlet. This filter will not normally require service and does not need to be replaced when changing the hydraulic fluid.

1.32 Changing Hydraulic Fluid & Filter

All oils eventually shear or thin out with use, reducing their lubricating ability. In addition, heat, oxidation, and contamination may cause the formation of sludge, gum, or varnish in the system. For these reasons, it is important to change the hydraulic oil at specified intervals. See Section 1.21 *Maintenance Schedule*.

1. Remove filler cap **(b)** from top of hydraulic tank.
2. Remove drain plug **(d)** and allow hydraulic fluid to drain.
3. Unscrew the return line filter **(e)** and replace filter cartridge.
4. Install drain plug.
5. Fill hydraulic tank through filler port with clean hydraulic fluid.
6. Bleed hydraulic system as described in Section 1.33.

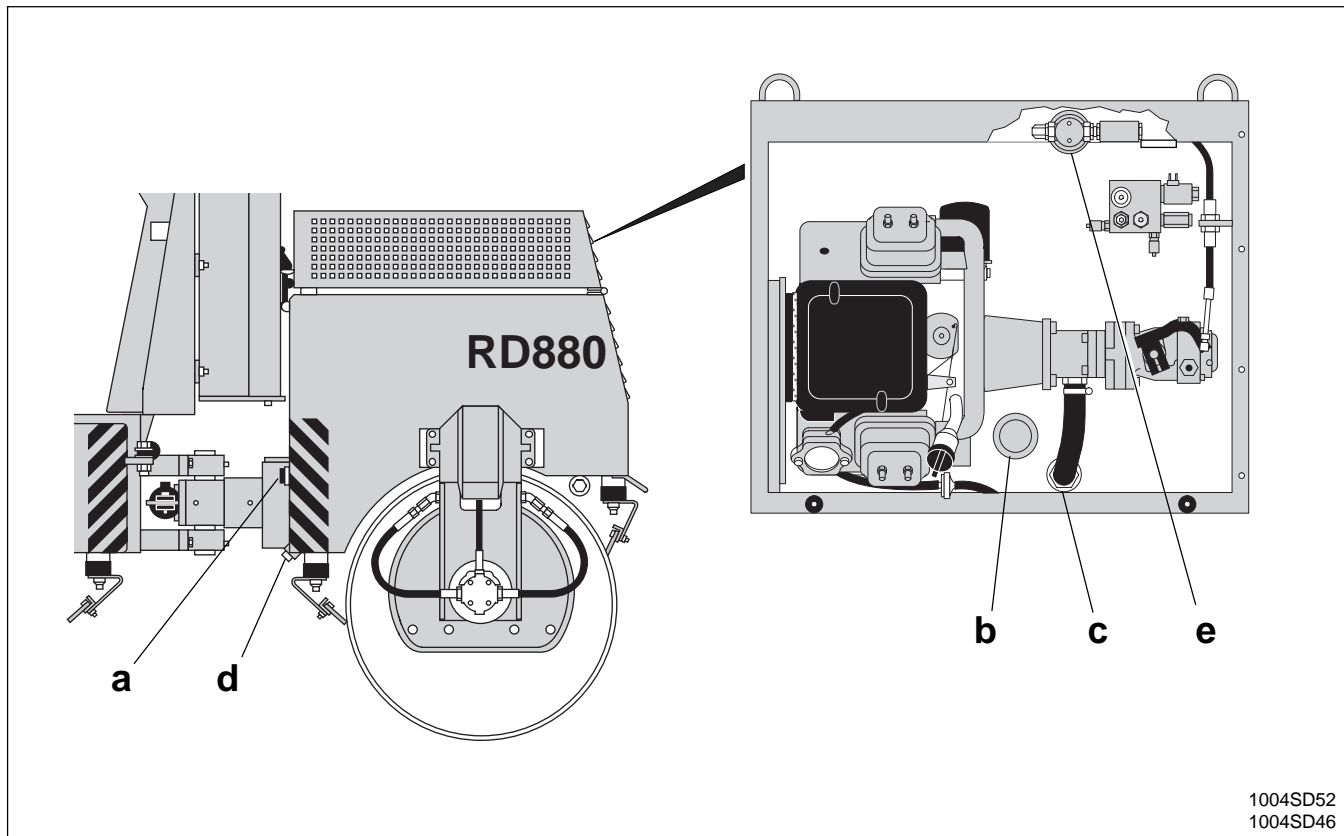

1004SD52
1004SD46

1.33 Bleeding the Hydraulic System

1. Fill the hydraulic system with clean hydraulic fluid until it is visible in the sight glass. **Do not** re-use used hydraulic fluid.
2. Remove case plug **(f)** or disconnect case drain line **(g)** from drive pump. Fill pump case with hydraulic fluid through open connection. Close connection.
3. Disconnect spark plug wires to prevent engine from starting and crank engine 5-10 seconds. This will allow oil to fill inlet lines.
4. Place forward/reverse control lever in **NEUTRAL**. Start engine and run machine at idle for 3-4 minutes.
5. With engine still running at idle, move control slowly back and forth from forward to reverse for a short time to bleed air trapped in drive circuit.
6. Gradually increase engine speed to full throttle and operate all controls to bleed remaining air from hydraulic lines.
7. Check hydraulic fluid level and add oil as required.

Note: If drive pump chatters or operation is noisy, turn machine off and check for air leaks in the inlet line to charge pump.

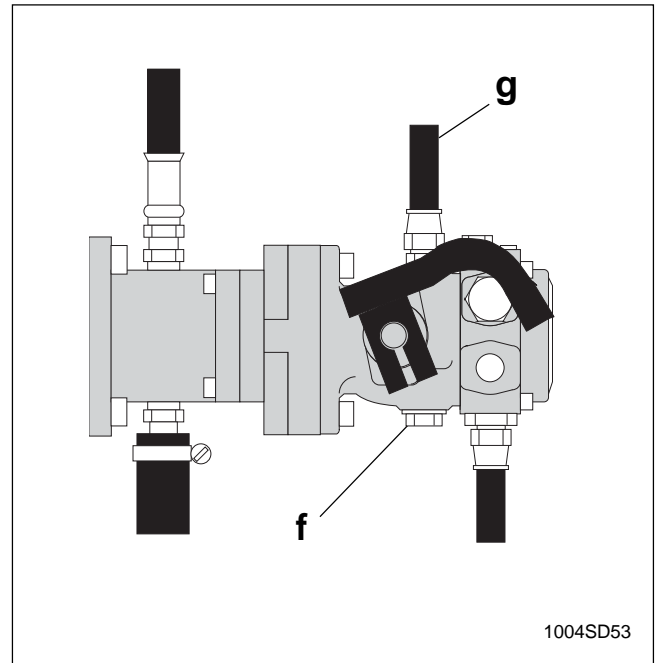

1.34 Scraper Bars

Scraper bars, located in front of and behind each drum, are used to prevent dirt and asphalt from sticking to and accumulating on the drum surface. These bars must be adjusted periodically as they wear.

To adjust scraper **(h)**, loosen the locknut **(i)** under the shockmounts **(j)** on each side of the drum. Push assembly toward drum until scraper bar firmly contacts drum surface.

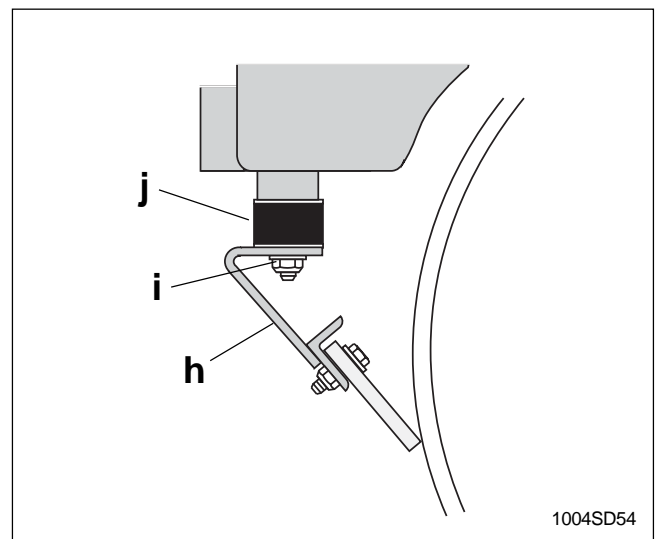

1.35 Towing

The drive circuit is equipped with a towing valve to allow oil to bypass the drive motors and let the roller freewheel for towing.

The towing valve should be used in emergency cases where the machine has become bogged down in loose or muddy soil, or cannot be driven due to an engine or hydraulic system failure.

To open bypass, shut engine off and loosen jam nut **(b)** one full turn counterclockwise. Then turn valve **(a)** one full turn counterclockwise.

When resuming machine operation, make sure by-pass is closed tightly. Turn valve **(a)** clockwise until fully seated. Then secure valve with jamnut **(b)**. If valve is not closed **completely**, the drive system may not respond or may perform sluggishly.

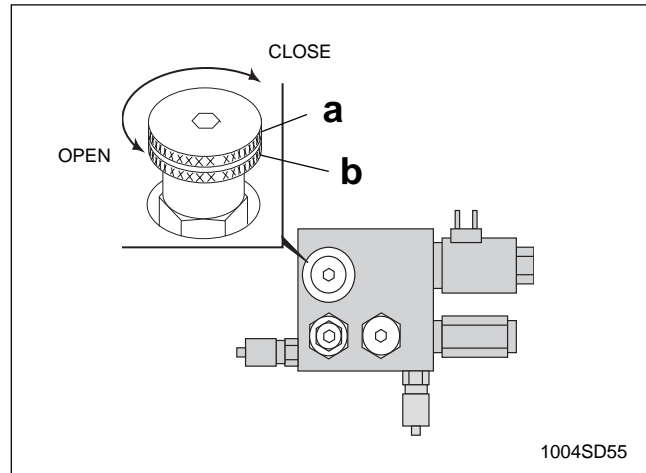

WARNING

With the tow valve open, the drive circuit has no braking action and the machine will roll freely. Close valve **immediately** after towing operation is complete to prevent machine from rolling unexpectedly.

CAUTION: Do not tow the roller long distances or at speeds greater than 2–3 mph. Damage to the drive motors may occur.

1.36 Storage

If unit is to be stored for more than 30 days:

1. Drain fuel tank and water tank. Also drain rear drum, if ballast was added.
2. Open water valves and drain water from sprinkling system.
3. Change engine oil.
4. Remove spark plugs and pour approximately 1 ounce (3 ml) of SAE 30W oil into each engine cylinder through spark plug opening.
5. Install spark plugs. Leave ignition wires disconnected to prevent engine from starting. Crank engine for one or two seconds to distribute oil inside engine cylinders. Connect ignition wires.
6. Clean entire roller and engine compartment.
7. Remove dirt from cooling fins on engine cylinders and on blower housing.
8. Set lockarm to secure roller halves together.
9. Cover entire machine and place in a dry, protected area.
10. Remove battery from machine and charge it periodically.

1.37 Hydraulic Diagram

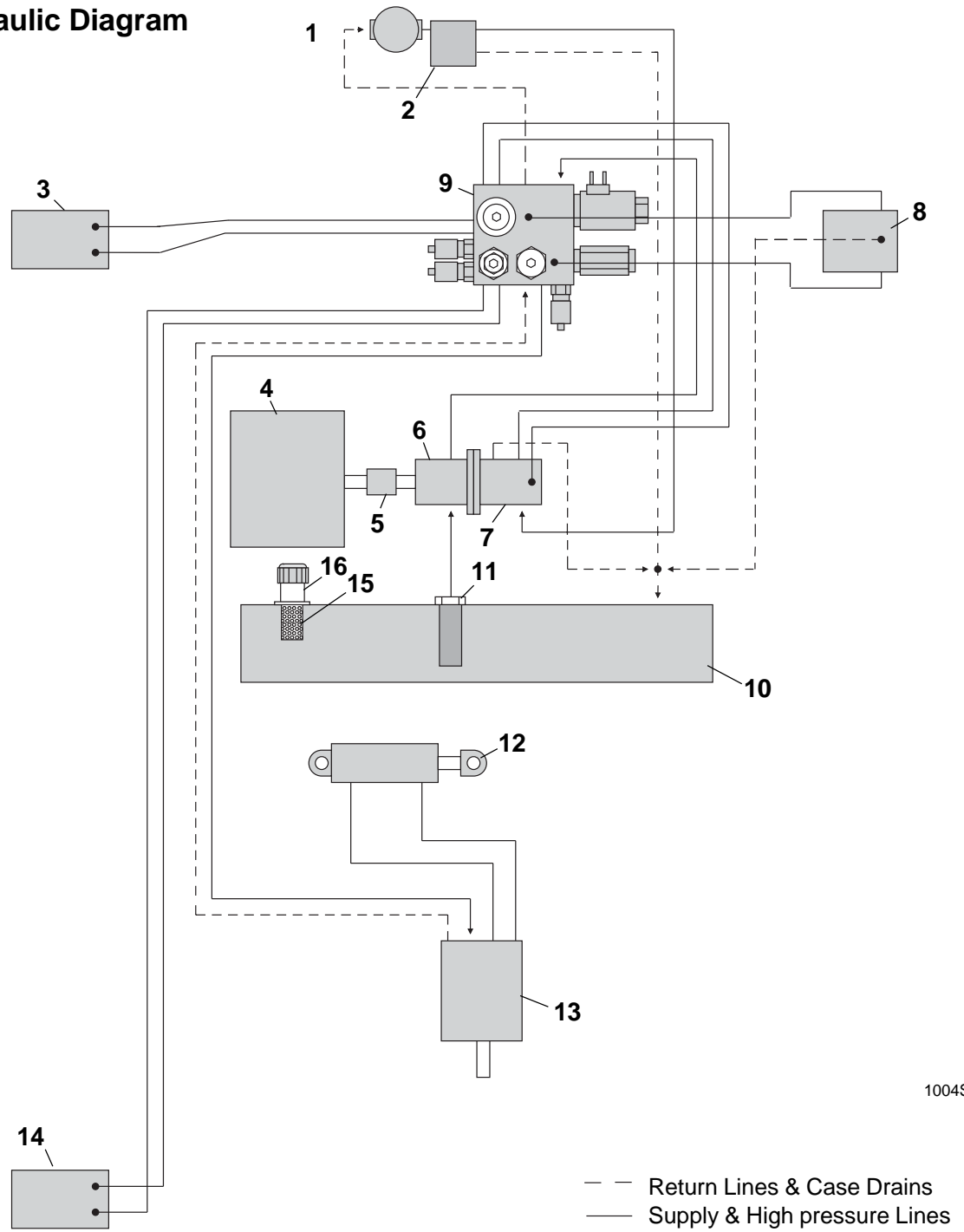

1004SD56

Ref	Description
1	Return Line Filter (10 Micron)
2	Back Pressure Valve
3	Front Drive Motor
4	Engine
5	Coupling
6	Exciter Pump
7	Drive Pump
8	Exciter Motor

Ref	Description
9	Manifold Block
10	Hydraulic Tank
11	Suction Filter
12	Steering Cylinder
13	Steering Valve
14	Rear Drive Motor
15	Trap
16	Fill Port

1.38 Hydraulic Schematic

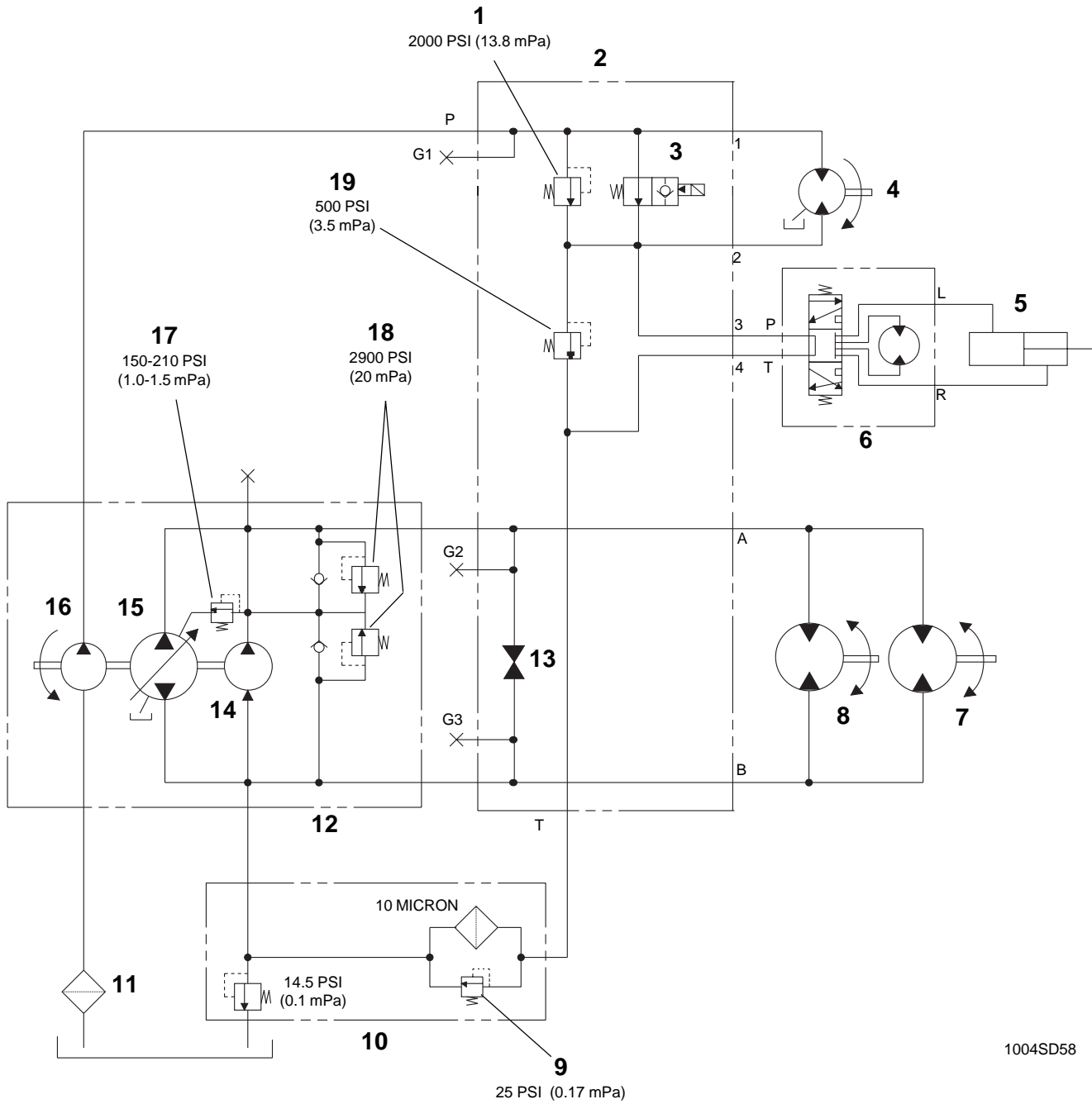

1004SD58

Ref	Description
1	Exciter Relief Valve
2	Manifold
3	Exciter Valve
4	Exciter Motor
5	Steering Cylinder
6	Steering Valve
7	Rear Drive Motor
8	Front Drive Motor
9	Filter By-pass

Ref	Description
10	Return Line Filter Assembly
11	Suction Filter
12	Pump Assembly
13	Towing Valve
14	Charge Pump
15	Drive Pump
16	Exciter Pump
17	Charge Pressure Relief Valve
18	Internal Drive pump Relief Valves
19	Steering Relief Valve

1.39 Wiring Diagram

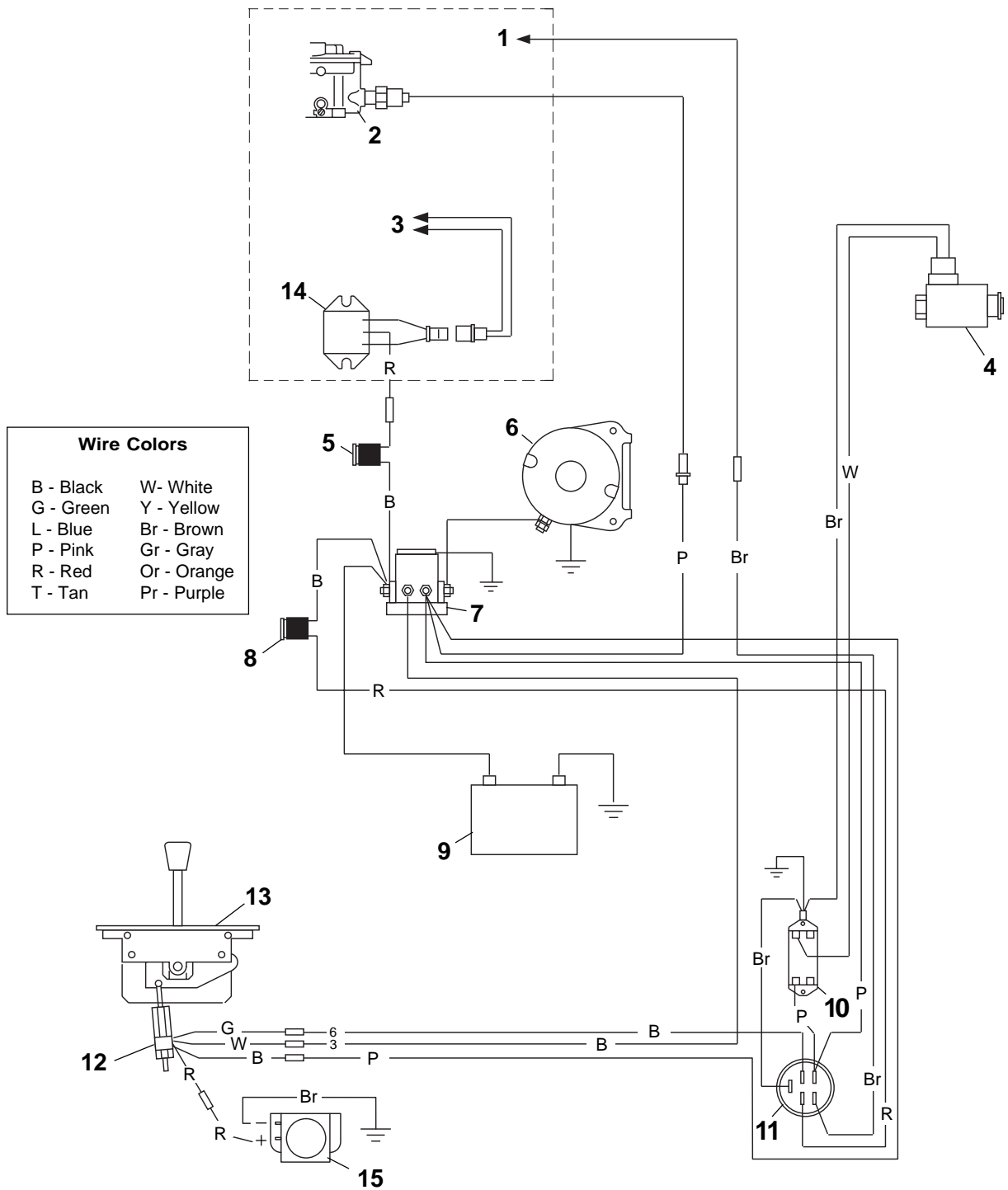

1004SD85

Ref	Description	Ref	Description
1	To Magneto Kill	8	10 Amp Fuse
2	Anti-Afterfire Solenoid	9	Battery
3	To Alternator	10	Vibration Switch
4	Exciter Solenoid	11	Ignition Switch
5	15 Amp Fuse	12	Neutral Safety Switch
6	Starter	13	Forward/Reverse Control
7	Starter solenoid	14	Rectifier Regulator
		15	Backup Alarm (optional)

1.40 Electrical Schematic

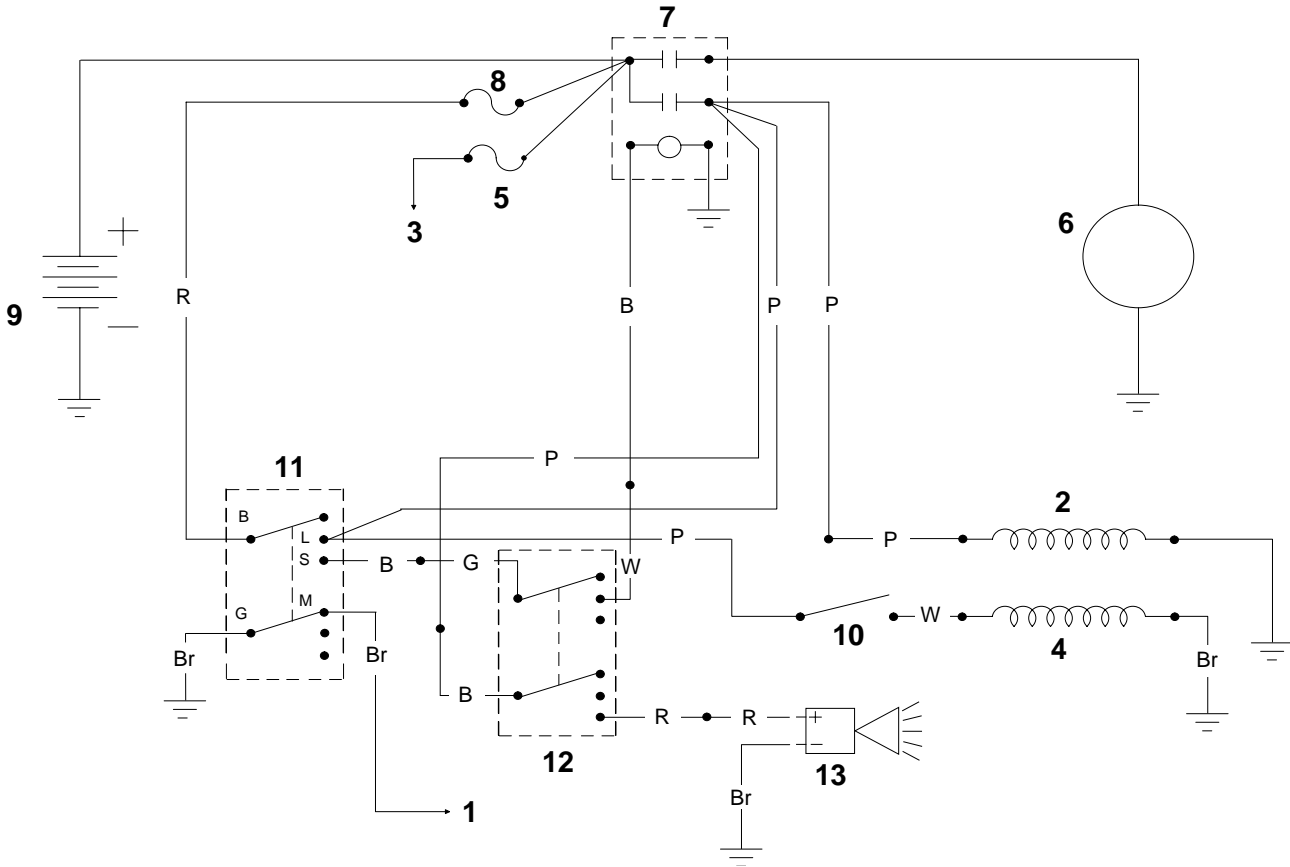

Wire Colors	
B - Black	W- White
G - Green	Y - Yellow
L - Blue	Br - Brown
P - Pink	Gr - Gray
R - Red	Or - Orange
T - Tan	Pr - Purple

1004SD79

Ref	Description	Ref	Description
1	To Magneto Kill	7	Starter Solenoid
2	Anti-Afterfire Solenoid	8	10 Amp Fuse
3	To Alternator	9	Battery
4	Exciter Solenoid	10	Vibration Switch
5	15 Amp Fuse	11	Ignition Switch
6	Starter	12	Neutral Safety Switch
		13	Backup Alarm (optional)

1.40 Schéma électrique

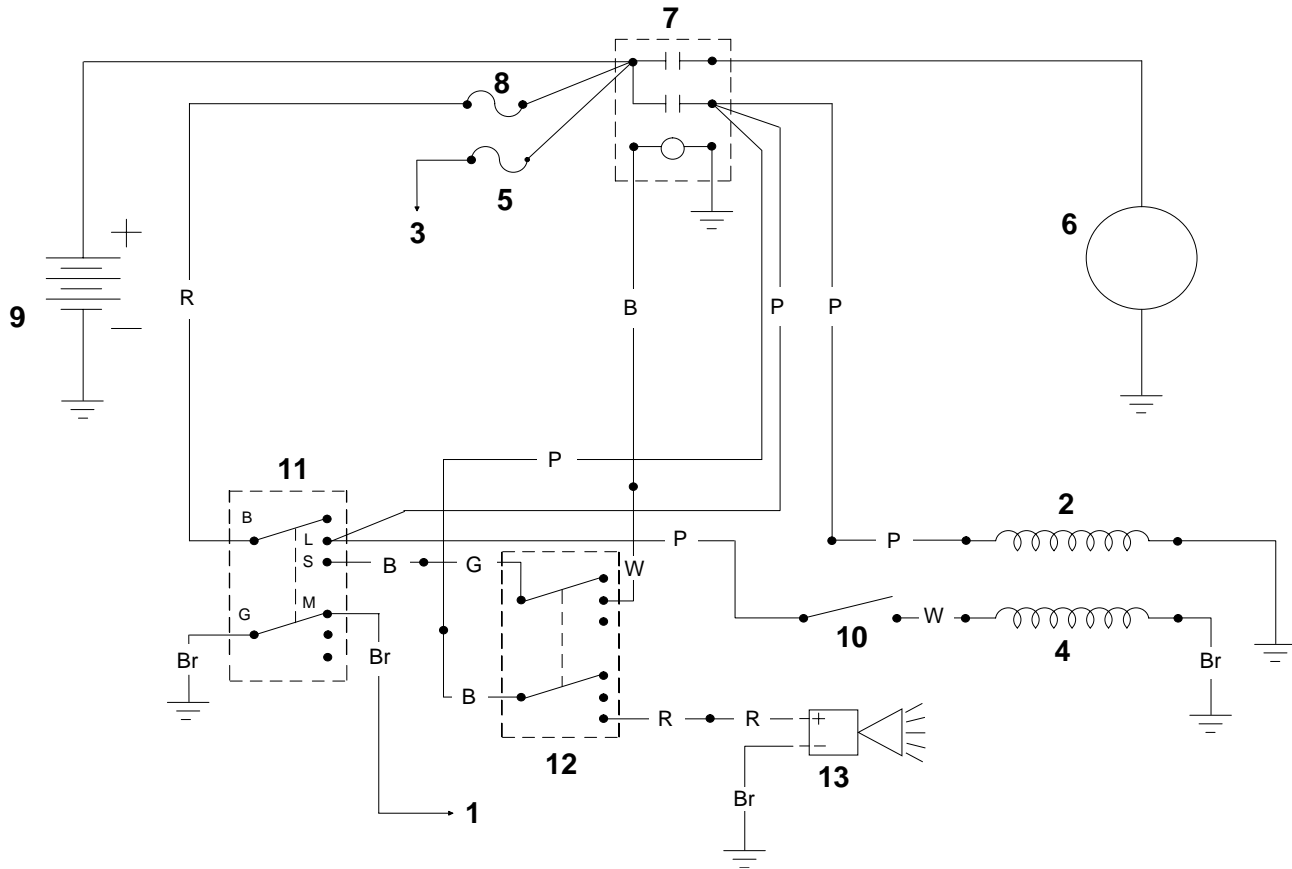

1004SD79

Couleurs des câbles			
B	Noir	W	Blanc
G	Vert	Y	Jaune
L	Bleu	Br	Marron
P	Rose	Gr	Gris
R	Rouge	Or	Orange
T	Beige	Pr	Violet

Réf.	Description
1	Vers le magnéto
2	Solénoïde de l'anti-auto-allumage
3	Vers l'alternateur
4	Solénoïde de l'excitateur
5	Fusible de 15 Amp
6	Démarrreur

Réf.	Description
7	Solénoïde du démarreur
8	Fusible de 10 Amp
9	Batterie
10	Commutateur de vibration
11	Contacteur d'allumage
12	Commutateur de sécurité point mort
13	Avertisseur de marche arrière (optionnel)