

 **WARNING**

- Read and understand all operating instructions before use.
- The vehicle must be properly supported and blocked before starting repairs.
- Use a transmission jack of the proper size and capacity to handle the anticipated load. This jack is rated for a maximum load of 2,000 lbs. Do not overload beyond the jack's rated capacity. Overloading may cause damage to or failure of the jack.
- Keep hands, fingers, and arms away from moving parts of the jack at all times.
- Secure the load with the safety chain before lowering or moving the load.
- Lower the load slowly and avoid sudden starts or stops that may cause the load to shift.
- This jack is designed for use only on hard, level surfaces capable of sustaining the load. Use on other than hard, level surfaces can result in jack instability and possible loss of load.
- Do not use the transmission jack if under the influence of alcohol or drugs.
- This transmission jack is designed and intended for use by properly trained and experienced personnel only. If you are not familiar with the proper and safe operation of a transmission jack, do not use until proper training and knowledge have been obtained.
- The use of this jack is limited to the removal, installation, and transportation in the lowered position, of transmissions and differentials.
- Failure to comply with all of these warnings may cause loss of load, damage to the jack, and/or failure of the jack resulting in serious injury and/or property damage.

Specifications:

TJ-2000X

Stock Number.....	450077
Capacity	2,000 lbs.
Minimum Height	8-1/2"
Maximum Height	30-1/2"
Sideways Adjustment L/R	30°/30°
Forward/Backward Tilt	60°/17°
Saddle Size	7-3/4" x 7-3/4"
Base Size (LxW).....	35" x 19"
Net Weight	175 lbs.
Shipping Weight	184 lbs.

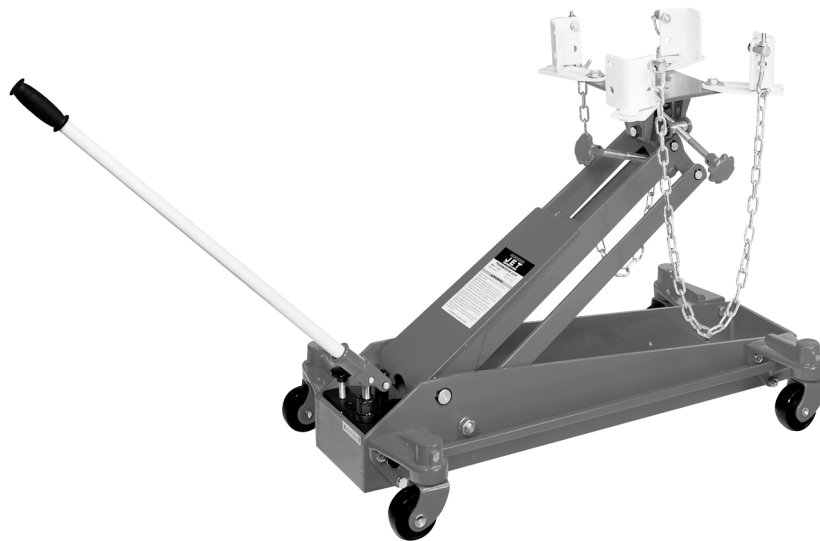

The specifications in this manual are given as general information and are not binding. JET Equipment & Tools reserves the right to effect, at any time and without prior notice, changes or alterations to parts, fittings, and accessory equipment deemed necessary for any reason whatsoever.

Assembly

All numbers in parenthesis () refer to the index number from the parts breakdown.

1. Mount the four angle brackets (100) to the saddle (94) using four hex cap screws (102), and four washers (101).
2. Insert four hook guides (91) into the angle bracket holes and tighten using four washers (96) and four hex nuts (95).
3. Place two chain screws (90) through hook guides and thread into chain connectors (92).
4. Thread hex nut (98) part way up the chain hook (99) followed by a washer (97). Place through hook guides and attach with washer (91), and hex nut (98). Repeat for second chain hook.
5. Screw pump handle (2) into handle socket (5).
6. Turn gear (32) clockwise to close the pump release valve. Pump handle up and down to lift the whole stroke. Turn gear (31) counter-clockwise for lowering. Test jack raising and lowering operation several times before use.

Operation

All numbers in parenthesis () refer to the index number from the parts breakdown.

1. Move the jack into position.
2. Turn the gear (32) clockwise fully to close the valve.
3. Move the pump lever (2) up and down to raise the saddle.
4. Adjust the angle screws (75 & 88) to align with the shape of the transmission.
5. Adjust angle brackets (100) and chain (93) to secure the transmission on the saddle. Tighten hex cap screws (102).
6. Remove the transmission from the vehicle.
7. Turn gear (32) counter-clockwise slowly to lower the saddle. Always lower the saddle slowly. Always transport the load in the lowered position with the chains securely fastened.
8. Reverse this procedure when mounting the transmission.

Maintenance

1. The hydraulic cylinder assembly contains hydraulic fluid that must be kept at approximately 80% of full at all times for proper operation. To check the level and to fill, remove screw (26).
2. Fill with clean hydraulic fluid only.
3. Replace the screw.

Lubrication

1. Lubricate the shaft threads of the angle screw assembly (75 & 88) with #2 tube grease when necessary.
2. Lubricate grease fitting (78) once every three months, depending on usage, with #2 tube grease.