



A simple design and unparalleled user friendly features, BlueBird lifts bring quality to new heights

BlueBird lifts are a familiar sight at racetracks, garages, airports and marinas throughout the United States and abroad.

BlueBird products are an industry classic valued by racing teams, machine shops, hobbyists, rental stores and a wide range of industrial buyers for dependable performance in a broad range of challenging applications.

Craftsmanship:

Durable, versatile, and easy to use, BlueBird's knockdown lifts offer unparalleled features and performance.

Leg and column post sockets are sized for precision fit, making the lifts stable and easy to assemble, while interchangeable parts offer versatility and convenience.

The hook on the end of the boom turns 360 degrees, making it easy to pick up, load, and reposition objects.



Portable:



BlueBird knockdown lifts and engine stands can be taken apart in minutes making them easy to transport. They fit easily in a car trunk, a pickup truck or an elevator. On site, the lift assembles quickly and fits wherever it is needed.

Versatile:

BlueBird lifts handle some of the costliest engines in the world, and a host of other products and materials too, ranging from pianos to hospital equipment, building supplies and materials.



Knockdown Lifts

Kaydee knockdown lifts can be quickly taken apart, moved and assembled. They go wherever the job is – backyard, shop, warehouse, office tower or



construction site. For extra ease and portability, all parts of the Kaydee lifts can be moved in the wheeled Kaydee Kaddy, which is designed for easy handling by one person, and narrow enough to fit through a 20 inch opening.



Jacks

- Engineered to exacting specifications with a slow release valve that lets the load down slowly and gently
- Internal pressure relief valve prevents damage if the load exceeds rated capacity
- Chrome-plated ram resists seal-damaging rust and corrosion
- Rebuildable and easy to service



Van Lifts

The 1500 SL and 1200 SL Van Lifts with longer boom (62 inches on the 1200 SL) and lower column post (47½ inches) let users remove engines from the front as well as through the side door.

An optional engine grabber allows very close hook-up to the engine without chains. These lifts are also perfect for RVs and rear-engine buses. A standard Kaydee lift may be converted to a “SL” lift by substituting a short column post.



Towable Lifts

Designed for heavier applications, the Tip Tow 3000, Tip Tow II and Tip Tow 10 are engineered for perfect balance and easy towing with couplers that fit either 2” or 2¼” balls. The Tip Tow 3000 lifts up to 3,000 pounds and the Tip Tow II supports either 1,000 or 1,500 pounds from two lifting locations on the boom.

The Tip Tow 10 is perfect for situations where long reach and high lift are required. Boom hooks can be raised to a full 10 feet, making it the ideal lift for jacked-up 4x4’s, boat engines (even on trailers) and airplane engines. The unique gooseneck design lets users reach into engine compartments without touching the surrounding structure.



Shop Lifts

Non-towable versions of the Tip Tow lifts are available as shop lifts. They have the same quality features as the Towables, but without the towing wheels and coupler. These lifts are perfect for shops, warehouses, plants, or any location where towing capability is not required.

Tip Tow II

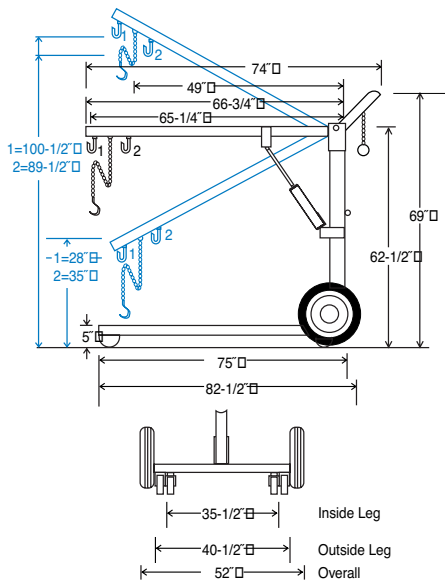

Tip Tow 3000

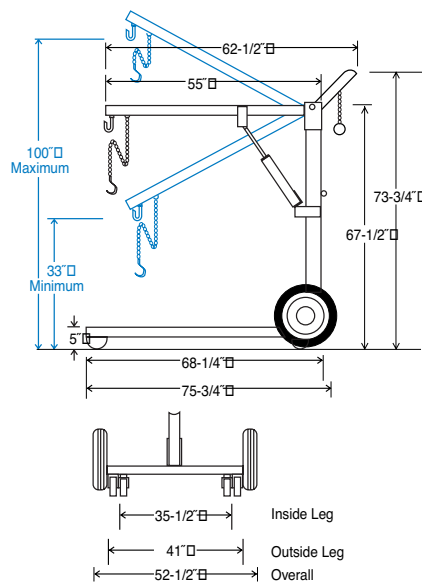

Tip Tow 10

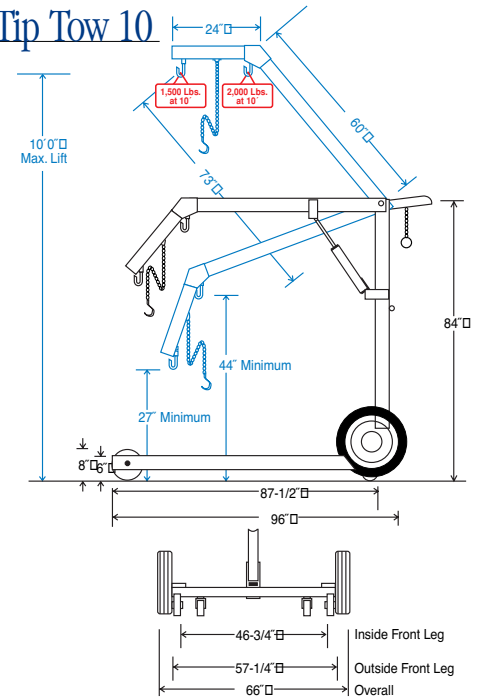

Towable Models

- The hooks on the booms are grab hooks so the chain may be adjusted to any height.
- The boom chains are long to hook into the base when towing to prevent the lift from "jack-knifing."
- The Tip Tow II and the Tip Tow 10 have two books on the boom with different lifting capacities:

	Outer Hook	Inner Hook
Tip Tow II	1000 Lbs.	1500 Lbs.
Tip Tow 10	1500 Lbs.	2000 Lbs.
Tip Tow 3000	Total Capacity 3000 Lbs.	

Towing wheels

Tip Tow II and Tip Tow 3000	4.80 x 8
Tip Tow 10	5.70 x 8
Bearings in tow wheel	high speed, tapered cone bearings.

Coupler on all models Standard-Fulton for 2" and 2-1/8" ball.
Optional - Croft cast steel for 2" and 2-1/8" ball.

Shipping Weights:

Tip Tow II	307 Lbs.
Tip Tow 3000	365 Lbs.
Tip Tow 10	530 Lbs.
Shop Lifts	Approx. 40 pounds less than the comparable towable model.

Shop Lifts have identical dimensions and specifications except they do not have towing wheels, spindles and coupler.

Kaydee 1200

Capacity - 1200 lbs.

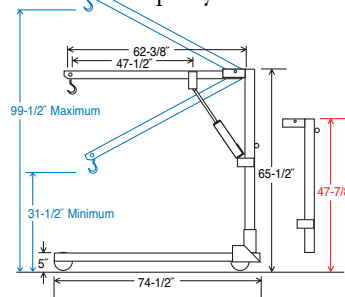

Kaydee 1500

Capacity - 1500 lbs.

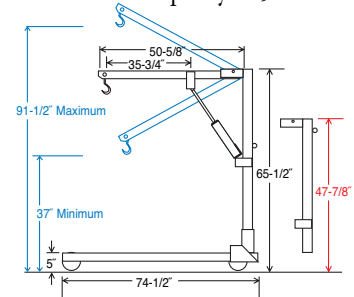

BlueBird International, Inc.
1400 East 66th Avenue
Denver, Colorado 80229 USA
PHONE 303-288-5880
TOLL FREE 1-800-808-BIRD (US only)
FAX 303-288-5899
TOLL FREE FAX 1-800-254-BIRD (US only)
WEBSITE www.bluebirdintl.com
EMAIL actioncenter@bluebirdintl.com

Kaydee Models

- Kaydee Lifts use a swivel slip hook at the end of the boom.

	Kaydee 1200	Kaydee 1500
• Shipping:		
Carton	9"x20"x76"	9"x20"x72"
Weight	294 Lbs.	279 Lbs.

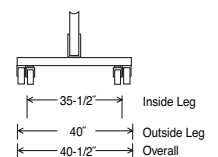

- Short Column Post converts any standard Kaydee Lift to a Van Lift.
- Engine Sling - adjustable, plated proof coil chain. Capacity 1250 lbs.